

10-7

Volume of Pyramids and Cones

Warm Up

Lesson Presentation

Lesson Quiz

10-7 Volume of Pyramids and Cones

Warm Up

Find the volume of each figure. Round to the nearest tenth, if necessary.

1. a square prism with base area 189 ft^2 and height 21 ft 3969 ft^3
2. a regular hexagonal prism with base edge length 24 m and height 10 m $14,964.9 \text{ m}^3$
3. a cylinder with diameter 16 in. and height 22 in. 4423.4 in^3

10-7 Volume of Pyramids and Cones

Objectives

Learn and apply the formula for the volume of a pyramid.

Learn and apply the formula for the volume of a cone.

10-7

Volume of Pyramids and Cones

The volume of a pyramid is related to the volume of a prism with the same base and height. The relationship can be verified by dividing a cube into three congruent square pyramids, as shown.

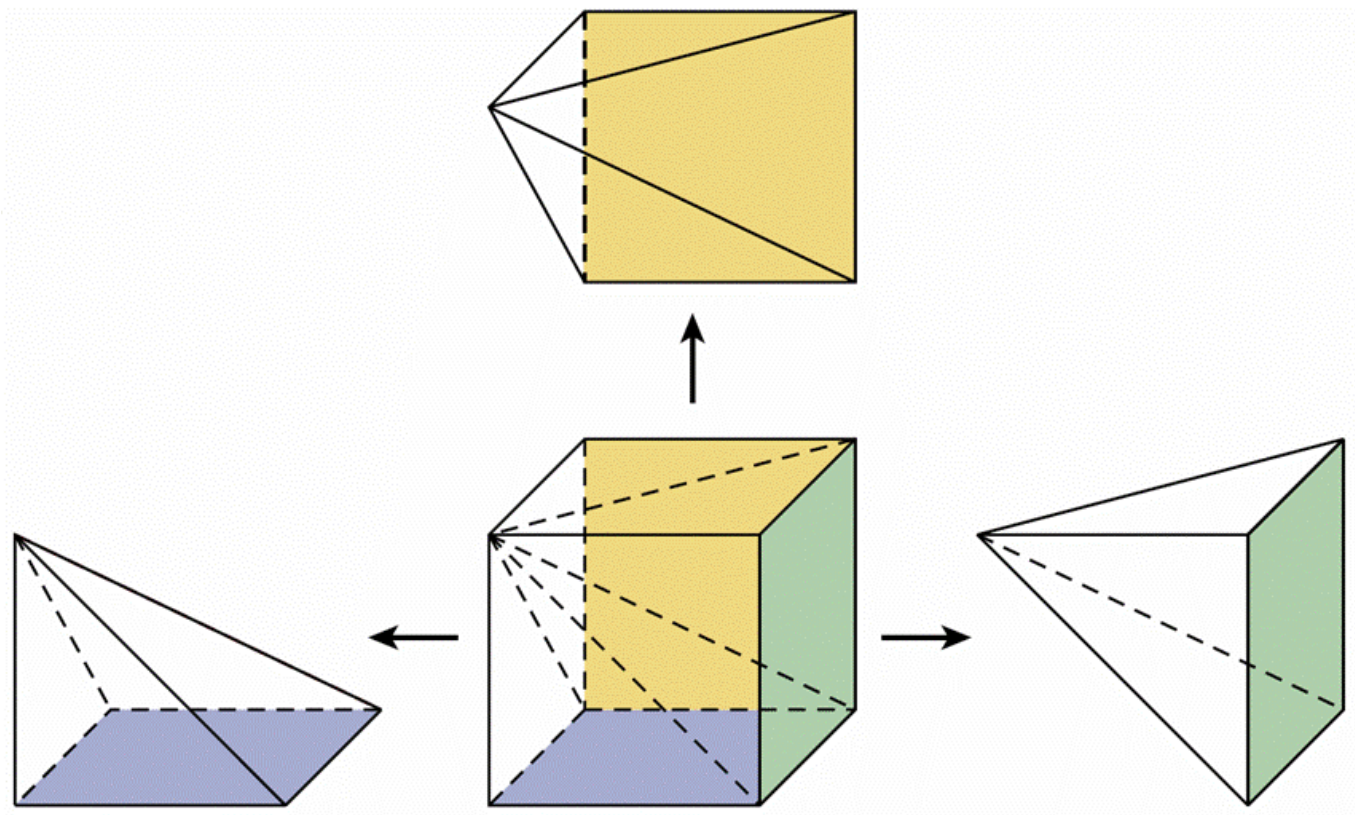

10-7 Volume of Pyramids and Cones

The square pyramids are congruent, so they have the same volume. The volume of each pyramid is one third the volume of the cube.

Volume of a Pyramid

The volume of a pyramid with base area B and height h is $V = \frac{1}{3}Bh$.

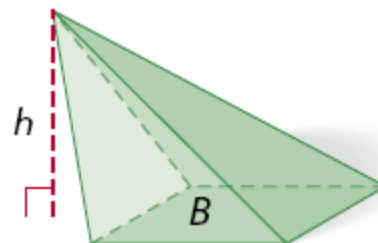
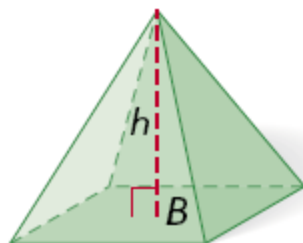

10-7 Volume of Pyramids and Cones

Example 1A: Finding Volumes of Pyramids

Find the volume a rectangular pyramid with length 11 m, width 18 m, and height 23 m.

$$V = \frac{1}{3}Bh = \frac{1}{3}(11 \cdot 18)(23) = 1518 \text{ m}^3$$

10-7 Volume of Pyramids and Cones

Example 1B: Finding Volumes of Pyramids

Find the volume of the square pyramid with base edge length 9 cm and height 14 cm.

The base is a square with a side length of 9 cm, and the height is 14 cm.

$$V = \frac{1}{3}Bh = \frac{1}{3}(9^2)(14) = 378 \text{ cm}^3$$

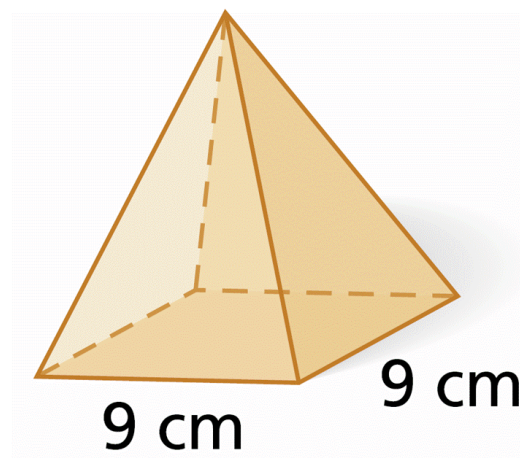

10-7 Volume of Pyramids and Cones

Example 1C: Finding Volumes of Pyramids

Find the volume of the regular hexagonal pyramid with height equal to the apothem of the base

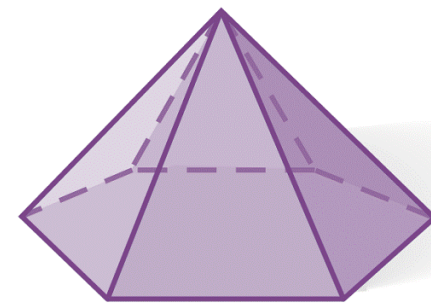

12 ft

Step 1 Find the area of the base.

$$B = \frac{1}{2}aP$$

Area of a regular polygon

$$= \frac{1}{2}(6\sqrt{3})(6(12))$$

Substitute $6\sqrt{3}$ for a and $6(12)$ for P .

$$= 216\sqrt{3} \text{ ft}^3$$

Simplify.

10-7 Volume of Pyramids and Cones

Example 1C Continued

Find the volume of the regular hexagonal pyramid with height equal to the apothem of the base

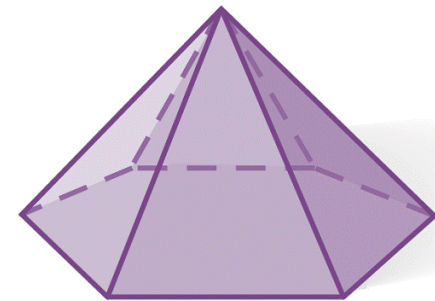

12 ft

Step 2 Use the base area and the height to find the volume. The height is equal to the apothem, $a = 6\sqrt{3}$ ft.

$$V = \frac{1}{3}Bh$$

Volume of a pyramid.

$$= \frac{1}{3}(216\sqrt{3})(6\sqrt{3})$$

Substitute $216\sqrt{3}$ for B and $6\sqrt{3}$ for h .

$$= 1296 \text{ ft}^3$$

Simplify.

10-7 Volume of Pyramids and Cones

Check It Out! Example 1

Find the volume of a regular hexagonal pyramid with a base edge length of 2 cm and a height equal to the area of the base.

Step 1 Find the area of the base.

$$B = \frac{1}{2}aP \quad \text{Area of a regular polygon}$$

$$= \frac{1}{2}(\sqrt{3})(6(2)) \quad \text{Substitute } \sqrt{3} \text{ for } a \text{ and } 6(2) \text{ for } P.$$

$$= 6\sqrt{3} \text{ cm}^2 \quad \text{Simplify.}$$

10-7 Volume of Pyramids and Cones

Check It Out! Example 1 Continued

Find the volume of a regular hexagonal pyramid with a base edge length of 2 cm and a height equal to the area of the base.

Step 2 Use the base area and the height to find the volume.

$$\begin{aligned} V &= \frac{1}{3}Bh && \text{Volume of a pyramid} \\ &= \frac{1}{3}(6\sqrt{3})(6\sqrt{3}) && \text{Substitute } 6\sqrt{3} \text{ for } B \text{ and } 6\sqrt{3} \text{ for } h. \\ &= 36 \text{ cm}^3 && \text{Simplify.} \end{aligned}$$

10-7 Volume of Pyramids and Cones

Example 2: Architecture Application

An art gallery is a 6-story square pyramid with base area $\frac{1}{2}$ acre (1 acre = 4840 yd², 1 story \approx 10 ft). Estimate the volume in cubic yards and cubic feet.

The base is a square with an area of about 2420 yd². The base edge length is $\sqrt{2420} \approx 49$ yd. The height is about $6(10) = 60$ ft or about 20 yd.

First find the volume in cubic yards.

$$V = \frac{1}{3}Bh \quad \text{Volume of a pyramid}$$

10-7 Volume of Pyramids and Cones

Example 2 Continued

$$V = \frac{1}{3}Bh$$

Volume of a pyramid

$$= \frac{1}{3}(2420)(20)$$

Substitute 2420 for B and 20 for h.

$$\approx 16,133 \text{ yd}^3 \approx 16,100 \text{ yd}^3$$

Then convert your answer to find the volume in cubic feet. The volume of one cubic yard is $(3 \text{ ft})(3 \text{ ft})(3 \text{ ft}) = 27 \text{ ft}^3$. Use the conversion factor $\frac{27 \text{ ft}^3}{1 \text{ yd}^3}$ to find the volume in cubic feet.

$$16,133 \text{ yd}^3 \cdot \frac{27 \text{ ft}^3}{1 \text{ yd}^3} \approx 435,600 \text{ ft}^3 \approx 436,000 \text{ ft}^3$$

10-7 Volume of Pyramids and Cones

Check It Out! Example 2

What if...? What would be the volume of the Rainforest Pyramid if the height were doubled?

$$V = \frac{1}{3}Bh$$

Volume of a pyramid.

$$= \frac{1}{3}(70)^2(66)$$

Substitute 70 for B and 66 for h.

$$= 107,800 \text{ yd}^3$$

$$\text{or } 107,800(27) = 2,910,600 \text{ ft}^3$$

10-7 Volume of Pyramids and Cones

Volume of Cones

The volume of a cone with base area B , radius r , and height h is $V = \frac{1}{3}Bh$,
or $V = \frac{1}{3}\pi r^2h$.

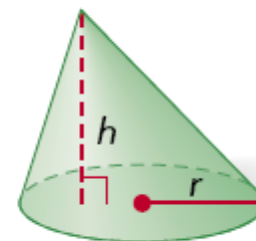
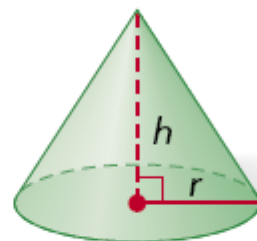

10-7 Volume of Pyramids and Cones

Example 3A: Finding Volumes of Cones

Find the volume of a cone with radius 7 cm and height 15 cm. Give your answers both in terms of π and rounded to the nearest tenth.

$$V = \frac{1}{3}\pi r^2 h \quad \textit{Volume of a pyramid}$$

$$= \frac{1}{3}\pi(7)^2(15) \quad \textit{Substitute 7 for r and 15 for h.}$$

$$= 245\pi \text{ cm}^3 \approx 769.7 \text{ cm}^3 \quad \textit{Simplify.}$$

10-7 Volume of Pyramids and Cones

Example 3B: Finding Volumes of Cones

Find the volume of a cone with base circumference 25π in. and a height 2 in. more than twice the radius.

Step 1 Use the circumference to find the radius.

$$2\pi r = 25\pi \quad \textit{Substitute } 25\pi \textit{ for the circumference.}$$

$$r = 12.5 \quad \textit{Solve for } r.$$

Step 2 Use the radius to find the height.

$$h = 2(12.5) + 2 = 27 \text{ in.} \quad \textit{The height is 2 in. more than twice the radius.}$$

10-7 Volume of Pyramids and Cones

Example 3B Continued

Find the volume of a cone with base circumference 25π in. and a height 2 in. more than twice the radius.

Step 3 Use the radius and height to find the volume.

$$V = \frac{1}{3}\pi r^2 h \quad \text{Volume of a pyramid.}$$

$$= \frac{1}{3}\pi(12.5)^2(27) \quad \text{Substitute 12.5 for } r \text{ and 27 for } h.$$

$$= 1406.25\pi \text{ in}^3 \approx 4417.9 \text{ in}^3 \quad \text{Simplify.}$$

10-7 Volume of Pyramids and Cones

Example 3C: Finding Volumes of Cones

Find the volume of a cone.

Step 1 Use the Pythagorean Theorem to find the height.

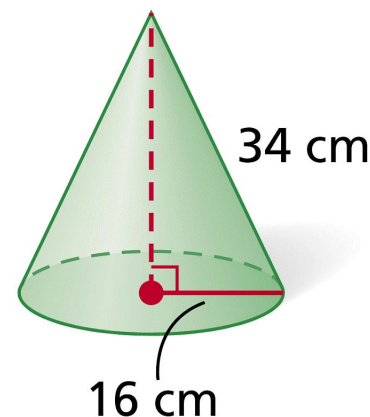

$$16^2 + h^2 = 34^2 \quad \textit{Pythagorean Theorem}$$

$$h^2 = 900 \quad \textit{Subtract } 16^2 \textit{ from both sides.}$$

$$h = 30 \quad \textit{Take the square root of both sides.}$$

10-7 Volume of Pyramids and Cones

Example 3C Continued

Find the volume of a cone.

Step 2 Use the radius and height to find the volume.

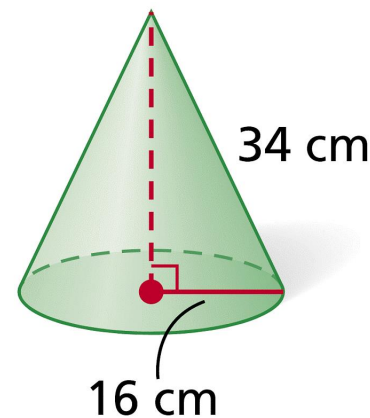

$$V = \frac{1}{3}\pi r^2 h \quad \text{Volume of a cone}$$

$$= \frac{1}{3}\pi(16)^2(30) \quad \text{Substitute 16 for } r \text{ and 30 for } h.$$

$$\approx 2560\pi \text{ cm}^3 \approx 8042.5 \text{ cm}^3 \quad \text{Simplify.}$$

10-7 Volume of Pyramids and Cones

Check It Out! Example 3

Find the volume of the cone.

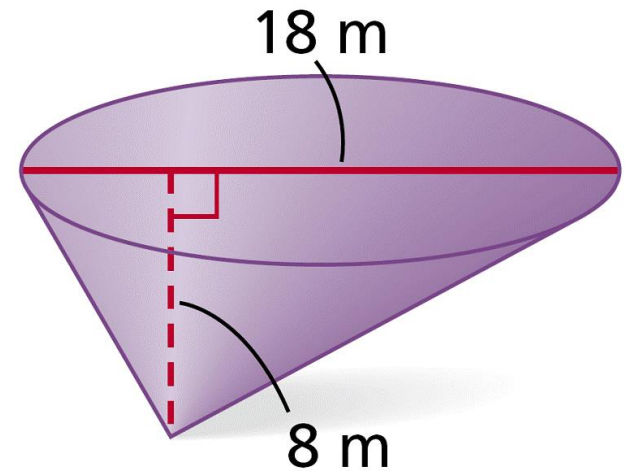

$$V = \frac{1}{3}\pi r^2 h$$

Volume of a cone

$$= \frac{1}{3}\pi(9)^2(8)$$

Substitute 9 for r and 8 for h.

$$\approx 216\pi \text{ m}^3 \approx 678.6 \text{ m}^3$$

Simplify.

10-7 Volume of Pyramids and Cones

Example 4: Exploring Effects of Changing Dimensions

The diameter and height of the cone are divided by 3. Describe the effect on the volume.

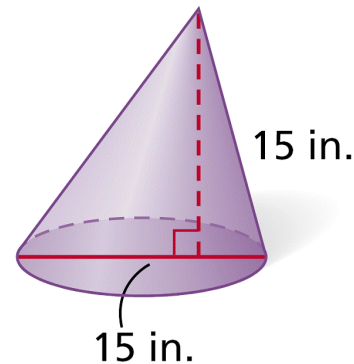

original dimensions:

$$\begin{aligned} V &= \frac{1}{3} \pi r^2 h \\ &= \frac{1}{3} \pi \left(\frac{15}{2} \right)^2 (15) = \frac{1125}{4} \pi \text{ in}^3 \end{aligned}$$

radius and height divided by 3:

$$\begin{aligned} V &= \frac{1}{3} \pi r^2 h \\ &= \frac{1}{3} \pi \left(\frac{5}{2} \right)^2 (5) = \frac{125}{12} \pi \text{ in}^3 \end{aligned}$$

Notice that $\frac{125}{12} \pi = \frac{1}{27} \left(\frac{1125}{4} \pi \right)$. If the radius and height are divided by 3, the volume is divided by 3^3 , or 27.

10-7 Volume of Pyramids and Cones

Check It Out! Example 4

The radius and height of the cone are doubled. Describe the effect on the volume.

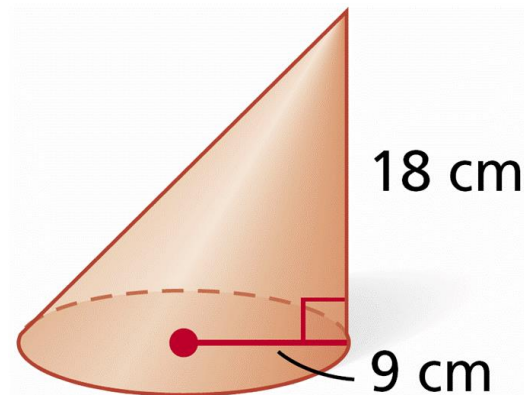

original dimensions:

radius and height doubled:

$$\begin{aligned} V &= \frac{1}{3}\pi r^2 h \\ &= \frac{1}{3}\pi (9)^2 (18) = 486\pi \text{ cm}^3 \end{aligned}$$

$$\begin{aligned} V &= \frac{1}{3}\pi r^2 h \\ &= \frac{1}{3}\pi (18)^2 (36) = 3888\pi \text{ cm}^3 \end{aligned}$$

The volume is multiplied by 8.

10-7 Volume of Pyramids and Cones

Example 5: Finding Volumes of Composite Three-Dimensional Figures

Find the volume of the composite figure. Round to the nearest tenth.

The volume of the upper cone is

$$\begin{aligned}V_{\text{upper}} &= \frac{1}{3}\pi r^2 h \\ &= \frac{1}{3}\pi(21)^2(70 - 35) = 5145\pi \text{ cm}^3.\end{aligned}$$

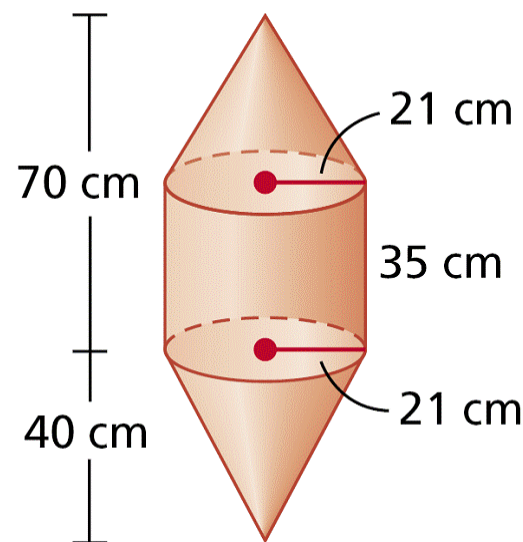

10-7 Volume of Pyramids and Cones

Example 5: Finding Volumes of Composite Three-Dimensional Figures

Find the volume of the composite figure. Round to the nearest tenth.

The volume of the cylinder is

$$V_{\text{cylinder}} = \pi r^2 h = \pi(21)^2(35) = 15,435\pi \text{ cm}^3.$$

The volume of the lower cone is

$$V_{\text{lower}} = \frac{1}{3}\pi r^2 h = \frac{1}{3}\pi(21)^2(40) = 5880\pi \text{ cm}^3.$$

The volume of the figure is the sum of the volumes.

$$V = 5145\pi + 15,435\pi + 5,880\pi = 26,460\pi \approx 83,126.5 \text{ cm}^3$$

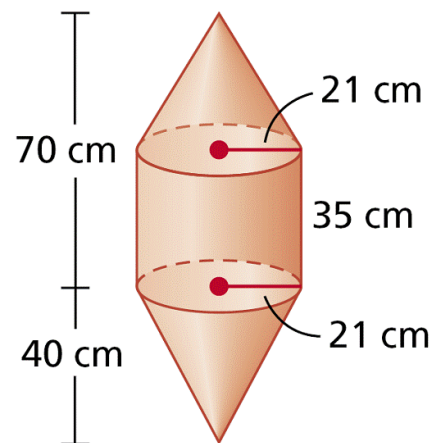

10-7 Volume of Pyramids and Cones

Check It Out! Example 5

Find the volume of the composite figure.

The volume of the rectangular prism is

$$V = \ell wh = 25(12)(15) = 4500 \text{ ft}^3.$$

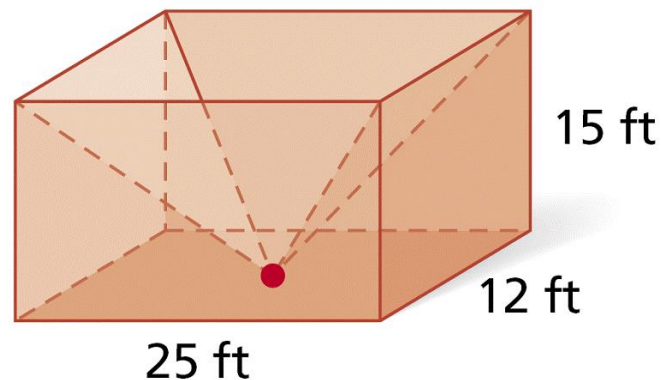

The volume of the pyramid is

$$\begin{aligned} V &= \frac{1}{3} Bh \\ &= \frac{1}{3} (12)(25)(15) = 1500 \text{ ft}^3. \end{aligned}$$

The volume of the composite is the rectangular prism subtract the pyramid.

$$4500 - 1500 = 3000 \text{ ft}^3$$

10-7 Volume of Pyramids and Cones

Lesson Quiz: Part I

Find the volume of each figure. Round to the nearest tenth, if necessary.

1. a rectangular pyramid with length 25 cm, width 17 cm, and height 21 cm 2975 cm^3
2. a regular triangular pyramid with base edge length 12 in. and height 10 in. 207.8 in^3
3. a cone with diameter 22 cm and height 30 cm
 $V \approx 3801.3 \text{ cm}^3$
4. a cone with base circumference 8π m and a height 5 m more than $\frac{1}{2}$ the radius
 $V \approx 117.3 \text{ m}^3$

10-7 Volume of Pyramids and Cones

Lesson Quiz: Part II

5. A cone has radius 2 in. and height 7 in. If the radius and height are multiplied by $\frac{1}{4}$, describe the effect on the volume.

The volume is multiplied by $\frac{1}{64}$.

6. Find the volume of the composite figure. Give your answer in terms of π .

$10,800\pi \text{ yd}^3$

